

LED Street Light

SL30 Series



Shenzhen LAMIN Optoelectronic Co., Ltd

9 Fu'rui Road, Dayangtian Development Zone, Fuyong Town,
Bao'an District, Shenzhen, Guangdong, 518103, China

 www.hklamin.com

SL30 Street Light



Convenient maintenance

Key Features

Global certified,ROHS,CE,ENEC,CB,UL,DLC,NOM

Cobra head with self-clean design, withstand storm upto 35m/s

With branded LEDs and driver, 140-160lm/w high efficiency

Reliable thermal design, $T_j < 85^{\circ}\text{C}$, $T_c < 70^{\circ}\text{C}$

IP66 dual ingress protection(lens+temper glass), IK09 guaranteed

Driver box and lighting part separately sealed, more efficient and safe

Super reliable, TM21 service life >63000hrs

Screw/Buckle-lock, push-in connectors for cable, easy maintenance

Support customized lighting demand via customized lenses and intelligent devices

Adjustable adaptor (0-20degree),suit adjusting demand of installation

Application

Street, road, stadium, highway, bridge, sport yard, parking.

Ordering Information

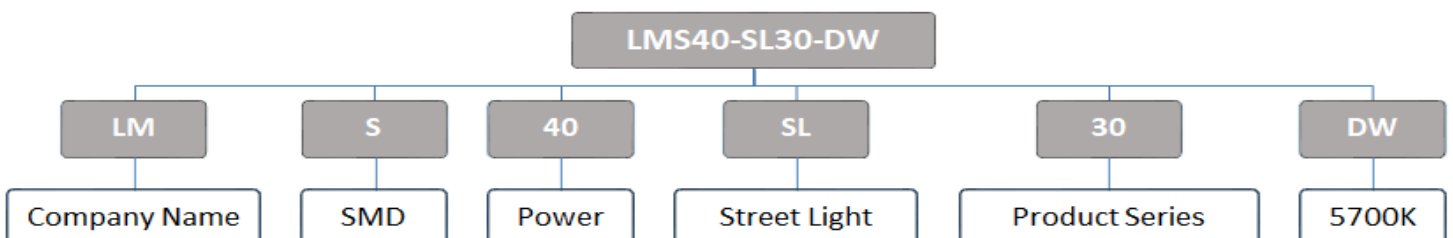

SL30 Street Light

Dimension (unit: mm)

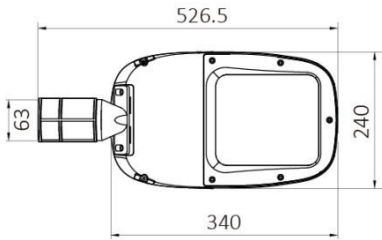

40W/50W/60W

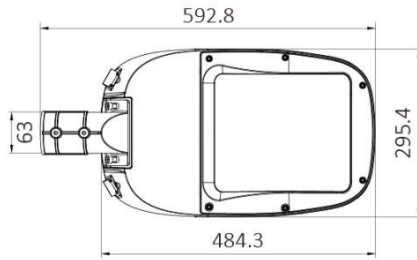

80W/100W/120W

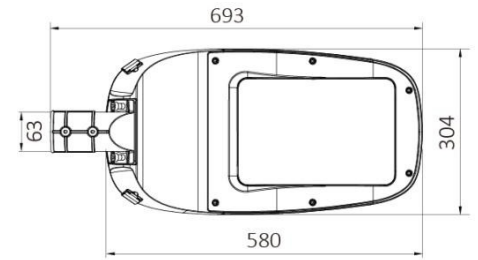

150W/200W

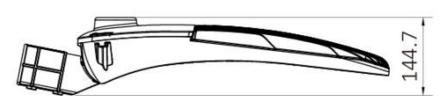
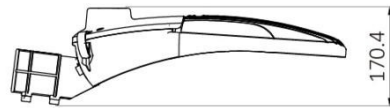
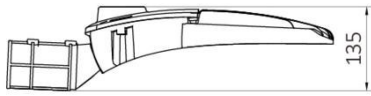

Product Data

Model	LMS40-SL30	LMS50-SL30	LMS60-SL30	LMS80-SL30	LMS100-SL30	LMS120-SL30	LMS150-SL30	SPS200-SL30
Wattage	40W	50W	60W	80W	100W	120W	150W	200W
Lumen Output	6000lm	7500lm	9000lm	12000lm	15000lm	18000lm	22500lm	29000lm
Luminous Efficacy	150lm/W							
CCT	3000K/4000K/5000K/5700K/6500K							
CRI	Ra≥70							
Input Voltage	100-277 VAC							
Housing Color	Light Silver							
Housing Material	Aluminum(ADC12), lens+temper glass							
Operating Temperature	-30°C to +45°C							
IP Level	IP65							
Lifespan	50,000 hours							
Warranty	5 years							

SL30 Street Light

Photometry

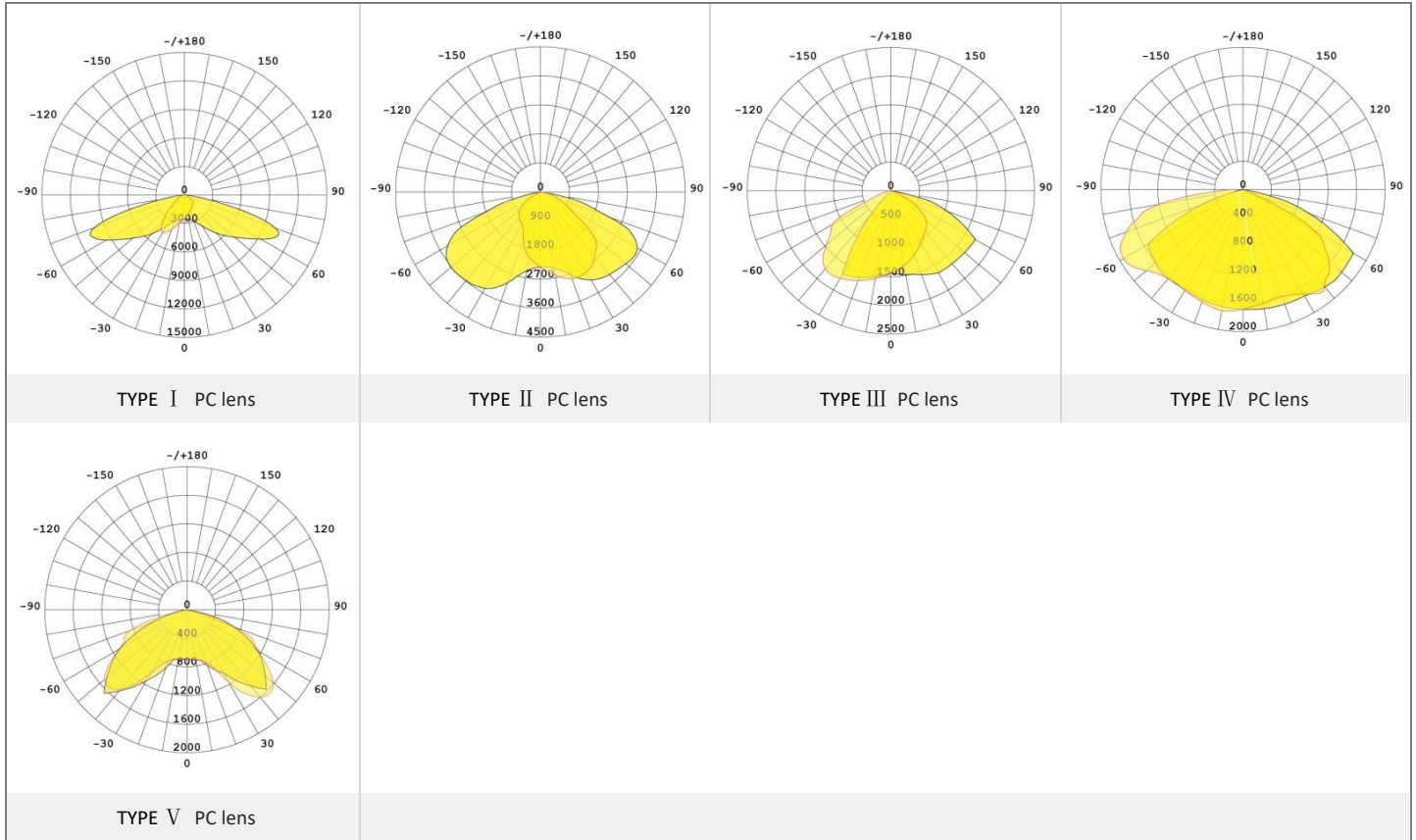

Packaging

Model	PCS/CTN	Net Weight	Gross weight	Volumetric Weight	CBM
LMS40-SL30	1	4.3kg	5.12kg	5.34kg	L580×W292×H197mm≈0.033 ³
LMS50-SL30	1	4.3kg	5.12kg	5.34kg	L580×W292×H197mm≈0.033 ³
LMS60-SL30	1	4.3kg	5.12kg	5.34kg	L580×W292×H197mm≈0.033 ³
LMS80-SL30	1	6.99kg	7.82kg	7.44kg	L649×W348×H238mm≈0.054 ³
LMS100-SL30	1	6.99kg	7.82kg	7.44kg	L649×W348×H238mm≈0.054 ³
LMS120-SL30	1	6.99kg	7.82kg	7.44kg	L649×W348×H238mm≈0.054 ³
LMS150-SL30	1	9.95kg	10.91kg	10.94kg	L746×W356×H225mm≈0.06 ³
LMS200-SL30	1	9.95kg	10.91kg	10.94kg	L746×W356×H225mm≈0.06 ³





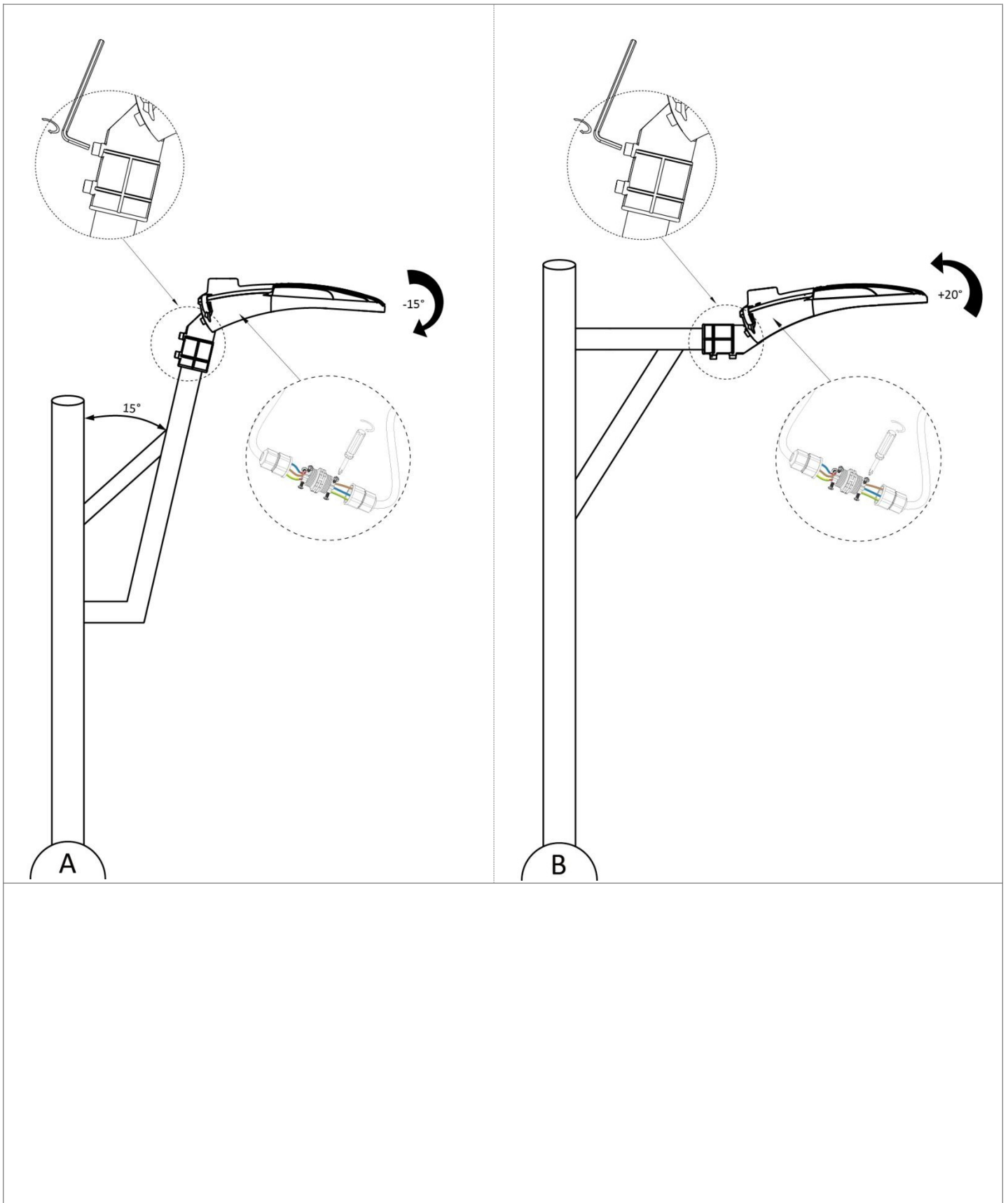

SL30 Street Light

Installation

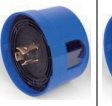
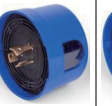
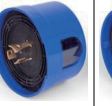

SL30 Street Light

Shorting cap & photocell

LED fixtures match	photocell options		controller base							
			JL-208	JL-205C	JL207C	JL241C	JL251C	JL254C	Gateway box(P/V)	
			"shorting cap Φ73X41MM IP66"	"Analog electronic control three-wire 6Lx ON 50Lx OFF 10s delay Φ84X66MM AC100-277V "	"Digital electronic control three-wire 16Lx ON 24Lx OFF 5-20s delay Φ84X66MM M AC100-277 V"		"0-10V dimming seven-wire 50Lx ON 50Lx OFF 10s delay Φ84X66MM AC100-277V "	"Dali dimming seven-wire 50Lx ON 50Lx OFF 10s delay Φ84X86MM AC100-277V "	"Zigbee control(need work with gateway box) Dali dimming Midnight Dimming LED Decay Compensati on seven-wire 50Lx ON 50Lx OFF 5s delay Φ84X86MM AC100-277V "	remote control by using a gateway box connected to a smart phone(iOS/An driod) with blue tooth communicati on, while connected to the smart control(JL-25 4C) with Zigbee communicati on
										
"SL27,SL29,SL30, SL32,SL30 series non-dimmable"	JL-200X		"S:Φ65X38.5MM,0-480VAC, AWG18#:10A, AWG14#:15A, ULapproval, 3-wire 150MM (match non-dimming)"	✓	✓	✓				
"SL27,SL29,SL30, SL32,SL30 series 0-10V dimmable"	JL-240XB		"S:Φ65X40MM,0-480VAC, AWG18#: 10A, AWG14:15A, ULapproval, 5-wire 150MM (match 0-10V dimming)"	✓			✓			
"SL27,SL29,SL30, SL32,SL30 series 0-10V/ Dali dimmable"	JL-240XA		"S:Φ65X40MM,0-480VAC, AWG18#:10A, AWG14#:15A, ULapproval,7-wire 150MM (match 0-10V/dalidimming)"	✓	✓	✓	✓	✓	✓	